



RM Cores

Series/Type: RM 6

The following products presented in this data sheet are being withdrawn.

| Ordering Code | Substitute Product | Date of Withdrawal | Deadline Last Orders | Last Shipments |
|-----------------|--------------------|--------------------|----------------------|----------------|
| B65808N1005D002 | B65808N1006D002 | 2003-08-08 | 2004-02-29 | 2004-08-31 |
| B65659F0001X101 | B65659F0001X023 | 2004-01-23 | | |
| B65821C1008T002 | B65821C1008T001 | 2003-08-08 | 2004-02-29 | 2004-08-31 |
| B65807C0000R026 | B65807C0000R048 | 2002-08-02 | 2002-12-31 | 2003-03-31 |
| B65807J0000Y042 | B65807J0000Y066 | 2002-08-02 | 2002-12-31 | 2003-03-31 |
| B65808K1006D002 | B65808N1006D002 | 2003-08-08 | 2004-02-29 | 2004-08-31 |

For further information please contact your nearest EPCOS sales office, which will also support you in selecting a suitable substitute. The addresses of our worldwide sales network are presented at www.epcos.com/sales.

RM 6
Core
B65807

- In accordance with IEC 60431
- Core without center hole for transformer applications
- RM cores are supplied in sets

Magnetic characteristics (per set)

| | with center hole | without center hole | |
|--------------|------------------|---------------------|------------------|
| $\Sigma l/A$ | 0,86 | 0,78 | mm ⁻¹ |
| l_e | 26,9 | 28,6 | mm |
| A_e | 31,3 | 36,6 | mm ² |
| A_{min} | — | 31 | mm ² |
| V_e | 840 | 1 050 | mm ³ |

Approx. weight (per set)

| m | 4,9 | 5,3 | g |
|-----|-----|-----|---|
| | | | |

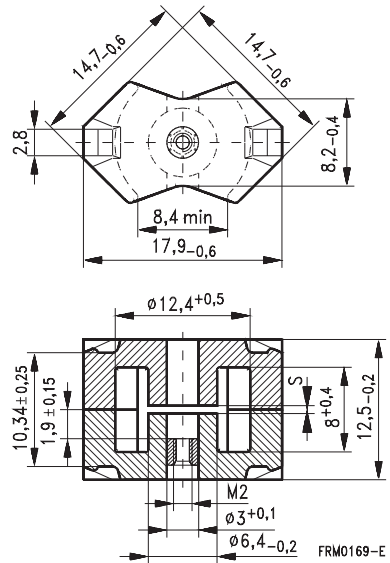
Gapped

| Material | A_L value nH | s approx. mm | μ_e | Ordering code ¹⁾ -J without center hole -N with threaded sleeve -C with center hole |
|----------|-------------------|----------------------|---------|---|
| K1 | $40 \pm 3 \%$ | 0,80 | 27,4 | B65807-+40-A1 |
| M33 | $63 \pm 3 \%$ | 0,60 | 43,2 | B65807-+63-A33 |
| | $100 \pm 3 \%$ | 0,38 | 68,5 | B65807-+100-A33 |
| N48 | $160 \pm 3 \%$ | 0,22 | 110 | B65807-+160-A48 |
| | $250 \pm 3 \%$ | 0,12 | 171 | B65807-+250-A48 |
| | $315 \pm 3 \%$ | 0,08 | 216 | B65807-+315-A48 |
| | $400 \pm 3 \%$ | 0,05 | 274 | B65807-+400-A48 |
| N41 | $250 \pm 3 \%$ | 0,17 | 155 | B65807-J250-A41 |

1) Replace the + by the code letter "C" or "N" for the required version. Standard version is "C".

Ungapped

| Material | A_L value nH | μ_e | A_{L1min} nH | P_V W/set | Ordering code -C with center hole -J w/o center hole |
|-------------------|-------------------|---------|-------------------|-------------------------------------|--|
| N26 | 2200 + 30/- 20 % | 1500 | | | B65807-C-R26 |
| N30 | 4300 + 30/- 20 % | 2670 | | | B65807-J-R30 |
| T57 ¹⁾ | 3500 + 30/- 20 % | 2180 | | | B65807-J-R57 |
| T38 | 8600 + 40/- 30 % | 5340 | | | B65807-J-Y38 |
| T42 | 12300 + 40/- 30 % | 7630 | | | B65807-J-Y42 |
| N49 | 1700 + 30/- 20 % | 1060 | 960 | < 0,15 (50 mT, 500 kHz, 100 °C) | B65807-J-R49 |
| N87 | 2400 + 30/- 20 % | 1490 | 1450 | < 0,51 (200 mT, 100 kHz, 100 °C) | B65807-J-R87 |
| N97 ¹⁾ | 2400 + 30/- 20 % | 1490 | 1450 | < 0,39 (200 mT, 100 kHz, 100 °C) | B65807-J-R97 |
| N41 | 3100 + 30/- 20 % | 1920 | 1450 | < 0,16 (200 mT, 25 kHz, 100 °C) | B65807-J-R41 |

1) Preliminary data

Coil former, squared pins

Material: GFR thermosetting plastic (UL 94 V-0, insulation class to IEC 60085: H \geq max. operating temperature 180 °C), color code black

Solderability: to IEC 60068-2-20, test Ta, method 1 (aging 3): 235 °C, 2 s

Resistance to soldering heat: to IEC 60068-2-20, test Tb, method 1B: 350 °C, 3,5 s

Winding: see "Processing Notes", page 153

For matching clamp and insulating washers see page 210.

| Sections | A_N mm ² | l_N mm | A_R value $\mu\Omega$ | Pins | Ordering code |
|----------|--------------------------|-------------|----------------------------|------------------|--|
| 1 | 15 | 30 | 69 | 4 5 6 6 | B65808-N1004-D1 B65808-N1005-D1 B65808-N1006-D1 B65808-W1006-D1 |
| 2 | 14 | 30 | 73 | 5 6 | B65808-N1005-D2 B65808-N1006-D2 |

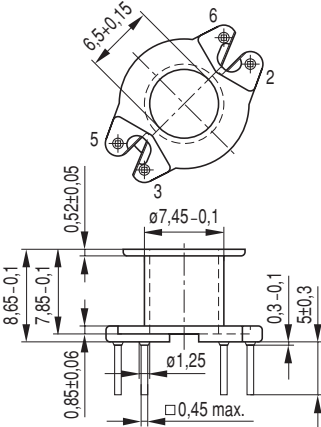
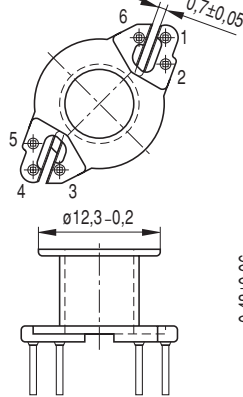
4 pins

5 + 6 pins

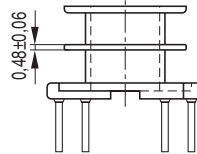
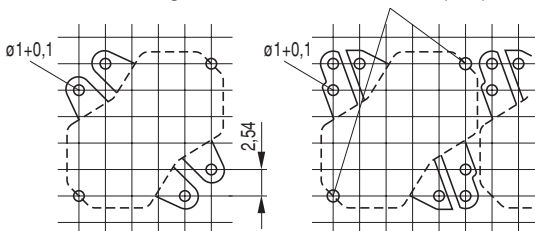
Pin 4 is omitted
in 5-pin version

Hole arrangement
View in mounting direction

FRM0267.4

50°±10°

Coil former, pins squared in the start-of-winding area

Material: GFR thermosetting plastic (UL 94 V-0, insulation class to IEC 60085:

H \geq max. operating temperature 180 °C), color code blue

Solderability: to IEC 60068-2-20, test Ta, method 1 (aging 3): 235 °C, 2 s

Resistance to soldering heat: to IEC 60068-2-20, test Tb, method 1B: 350 °C, 3,5 s

Winding: see "Processing Notes", page 153

For matching clamp and insulating washers see page 210.

| Sections | A_N mm ² | l_N mm | A_R value $\mu\Omega$ | Pins | Ordering code |
|----------|--------------------------|-------------|----------------------------|------|-----------------|
| 1 | 15 | 30 | 69 | 4 | B65808-K1004-D1 |
| | | | | 5 | B65808-K1005-D1 |
| | | | | 6 | B65808-K1006-D1 |
| 2 | 14 | 30 | 73 | 4 | B65808-K1004-D2 |
| | | | | 6 | B65808-K1006-D2 |

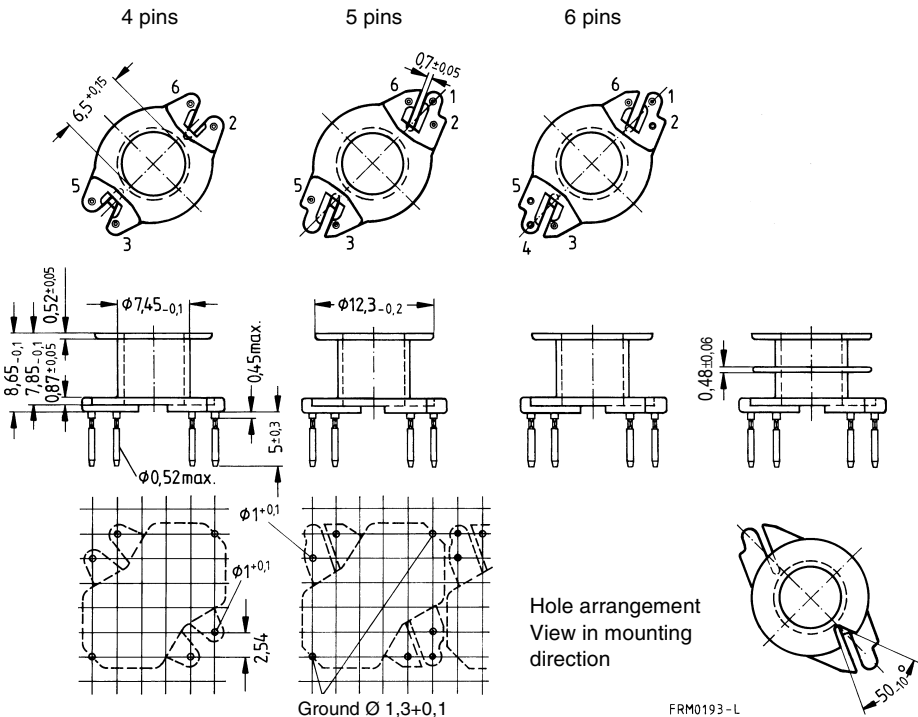

Coil former for SMPS transformers with line isolation

The creepage distances and clearances are designed such that the coil former is suitable for use in SMPS transformers with line isolation.

- Closed center flange with external wire guide
- Pins squared in the start-of-winding area
- Optimized for use with automatic winding machines

Material: GFR thermosetting plastic (UL 94 V-0, insulation class to IEC 60085:
F \triangleq max. operating temperature 155 °C), color code green

Solderability: to IEC 60068-2-20, test Ta, method 1 (aging 3): 235 °C, 2 s

Resistance to soldering heat: to IEC 60068-2-20, test Tb, method 1B: 350 °C, 3,5 s

Winding: see "Processing Notes", page 153

| Sections | A_N mm ² | l_N mm | A_R value $\mu\Omega$ | Pins | Ordering code |
|----------|--------------------------|-------------|----------------------------|------|-----------------|
| 2 | 14 | 30 | 73 | 8 | B65808-X1108-D2 |

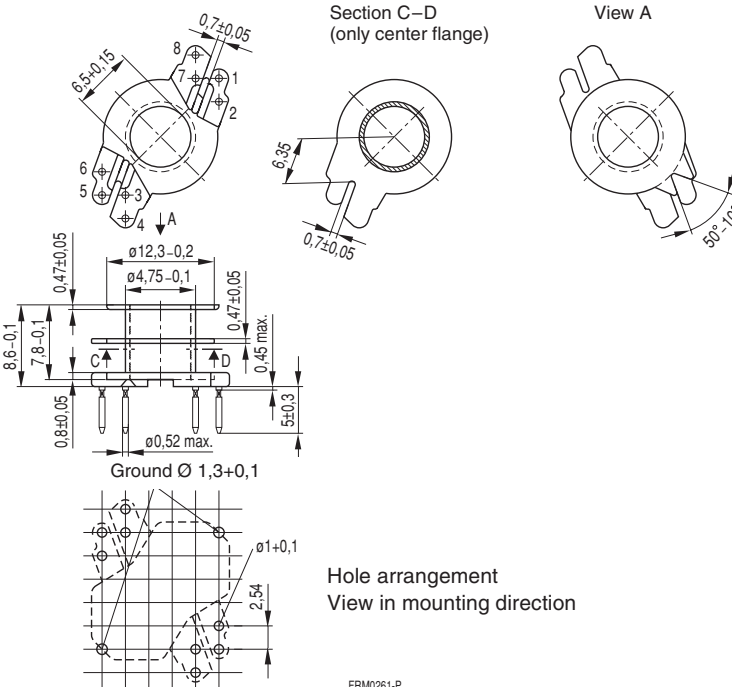

Coil former for power applications with angled pins

Optimized for automatic winding

Material: GFR polyterephthalate (UL 94 V-0, insulation class to IEC 60085:

 $F \triangleq$ max. operating temperature 155 °C), color code black

Solderability: to IEC 60068-2-20, test Ta, method 1 (aging 3): 235 °C, 2 s

Resistance to soldering heat: to IEC 60068-2-20, test Tb, method 1B: 350 °C, 3,5 s

Winding: see "Processing Notes", page 153

For matching clamp and insulating washer 1 see page 210

| Sections | A_N mm ² | l_N mm | A_R value $\mu\Omega$ | Pins | Ordering code |
|----------|--------------------------|-------------|----------------------------|------|-----------------|
| 1 | 15 | 30 | 69 | 8 | B65808-E1508-T1 |

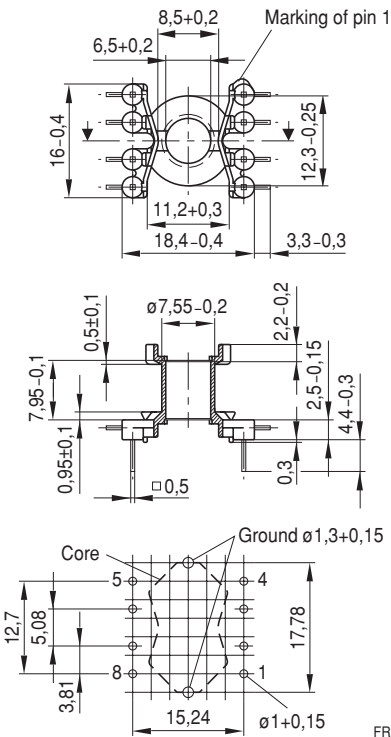
 Hole arrangement
View in mounting direction

FRM0298-Y

Coil former for power applications with straight pins

Optimized for automatic winding

Material: GFR polyterephthalate (UL 94 V-0, insulation class to IEC 60085:

 $H \triangleq$ max. operating temperature 180 °C), color code black

Solderability: to IEC 60068-2-20, test Ta, method 1 (aging 3): 235 °C, 2 s

Resistance to soldering heat: to IEC 60068-2-20, test Tb, method 1B: 350 °C, 3,5 s

Winding: see "Processing Notes", page 153

For matching clamp and insulating washer 1 see page 210

| Sections | A_N mm ² | l_N mm | A_R value $\mu\Omega$ | Pins | Ordering code |
|----------|--------------------------|-------------|----------------------------|------|-----------------|
| 1 | 15 | 30 | 69 | 8 | B65808-W1508-T1 |

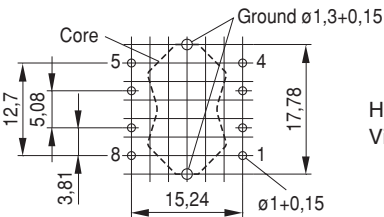
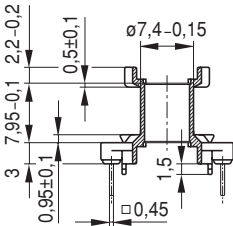
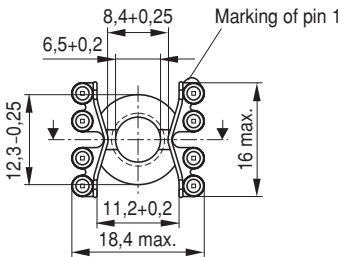
 Hole arrangement
View in mounting direction

FRM0299-7

Clamp

- With ground terminal, made of stainless spring steel (tinned), 0,435 mm thick
- Solderability to IEC 60068-2-20, test Ta, method 1 (aging 3): 235 °C, 2 s
- Also available as strip clamp on reels

Insulating washer 1 between core and coil former

- For tolerance compensation and for insulation
- Made of polycarbonate (UL 94 V-0, insulation class to IEC 60085: E \triangleq 120 °C), 0,08 mm thick

Insulating washer 2 for double-clad PCBs

- Made of polycarbonate (UL 94 V-0, insulation class to IEC 60085: E \triangleq 120 °C), 0,3 mm thick

| | Ordering code |
|---|---------------|
| Clamp (ordering code per piece, 2 are required) | B65808-A2203 |
| Insulating washer 1 (reel packing, PU = 1 reel) | B65808-A5000 |
| Insulating washer 2 (bulk) | B65808-C2005 |

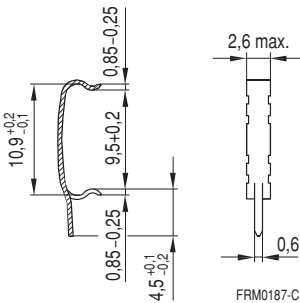
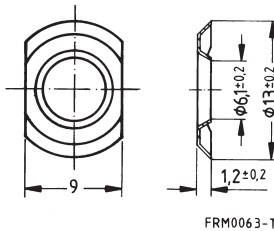
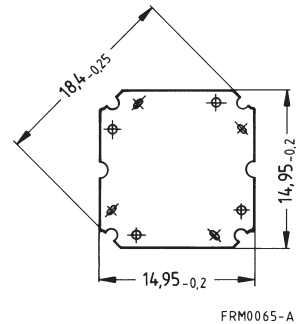
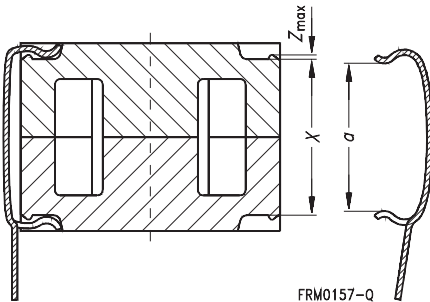
Clamp

Insulating washer 1

Insulating washer 2

Clamping forces for RM 6

F_{\min} : Extension of clamp from a to $a_2 = X_{\min}$
 F_{\max} : Extension of clamp from a to $a_1 = X_{\max}$

| | | |
|------------------------------|------------|------|
| Clamp opening a (mm) | 9,5 + 0,2 | |
| Core nose Z_{\max} (mm) | 0,22 | |
| Height of core pair X (mm) | X_{\min} | 10,1 |
| | X_{\max} | 10,6 |
| Clamping force F (N) | F_{\min} | 7 |
| | F_{\max} | 50 |



SMD coil former with gullwing terminals

Material: GFR liquid crystal polymer (UL 94 V-0, insulation class to IEC 60085:
F \triangleq max. operating temperature 155 °C), color code black

Solderability: to IEC 60068-2-20, test Ta, method 1 (aging 3): 350 °C, 1 s

Resistance to soldering heat: to IEC 60068-2-20, test Tb, method 1B: 350 °C, 3,5 s
permissible soldering temperature for wire-wrap connection on coil former: 400 °C, 1 s

Winding: see "Processing Notes", page 160

Clamp

- Without ground terminal, made of stainless spring steel, 0,435 mm thick
- Also available as strip clamp (each carton containing 2 reels) on request

| Sections | A _N mm ² | l _N mm | A _R value μΩ | Terminals | Ordering code |
|----------|---|----------------------|----------------------------|-----------|-----------------|
| 1 | 16,2 | 31 | 66 | 8 | B65821-C1008-T1 |
| 2 | 15,2 | 31 | 69 | 8 | B65821-C1008-T2 |
| Clamp | (ordering code per piece, 2 are required) | | | | B65808-J2204 |

Coil former

1 section

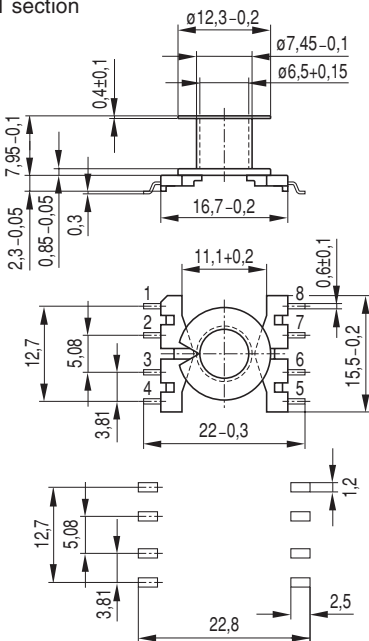

2 sections

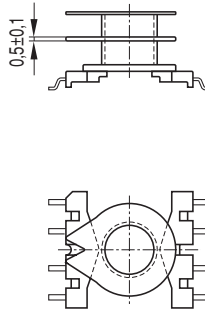

Recommended
PCB layout

FRM0238-Q

Clamp

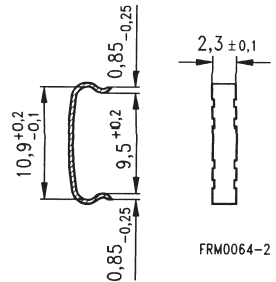

FRM0064-2

SMD

SMD coil former with J terminals

- Material: GFR liquid crystal polymer (UL 94 V-0, insulation class to IEC 60085:
 $F \triangleq$ max. operating temperature 155 °C), color code black
- Solderability: to IEC 60068-2-20, test Ta, method 1 (aging 3): 350 °C, 1 s
- Resistance to soldering heat: to IEC 60068-2-20, test Tb, method 1B: 350 °C, 3,5 s
 permissible soldering temperature for wire-wrap connection on coil former: 400 °C, 1 s
- Winding: see "Processing Notes", page 160

Clamp

- Without ground terminal, made of stainless spring steel, 0,435 mm thick
- Also available as strip clamp (each carton containing 2 reels) on request

| Sections | A _N mm ² | l _N mm | A _R value μΩ | Terminals | Ordering code |
|----------|---|----------------------|----------------------------|-----------|-----------------|
| 1 | 16,2 | 31 | 66 | 8 | B65821-J1008-T1 |
| Clamp | (ordering code per piece, 2 are required) | | | | B65808-J2204 |

Coil former

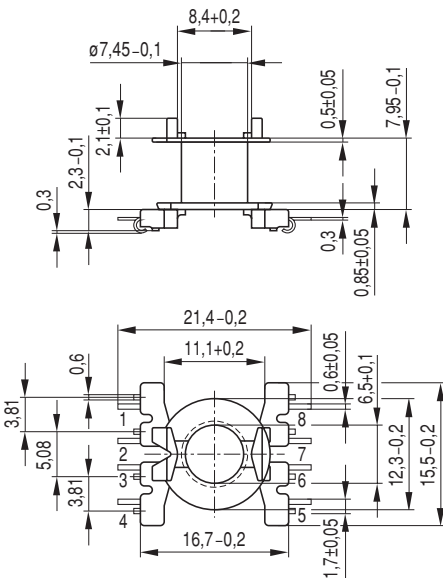

Clamp

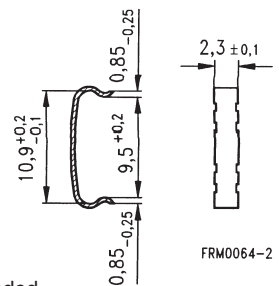

FRM0064-2

Recommended PCB layout

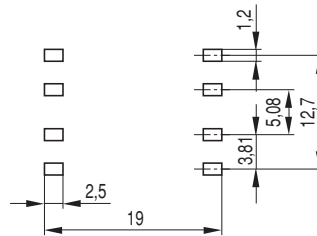

FRM0239-Y

| | |
|--------------------|---------------|
| RM 6 | B65659 |
| Accessories | B63399 |

Adjusting screw

- Tube core with thread and core brake made of GFR polyterephthalate
- Plastic **adjusting screwdriver** (not shown)
- Plastic **handle** for adjusting screwdriver (not shown)

| Core RM 6 | | Adjusting screw | | | | Min. adjusting range % | Ordering code |
|------------------------------|-------------------------|-----------------|-------------------------|----------|------------|------------------------|----------------|
| Material | A _L value nH | Fig. | Tube core Ø × length mm | Material | Color code | | |
| K 1 | 40 | a | 2,62 × 3,7 | Si 1 | white | 15 | B65659-F1-X101 |
| M 33 | 63 | a | 2,62 × 3,7 | Si 1 | white | 17 | B65659-F1-X101 |
| | 100 | c | 2,82 × 4,4 | Si 1 | brown | 16 | B65659-F4-X101 |
| N 48 | 160 | a | 2,62 × 3,7 | K 1 | green | 17 | B65659-F1-X1 |
| | 250 | a | 2,62 × 3,7 | N 22 | red | 11 | B65659-F1-X23 |
| | 315 | b | 2,75 × 4,4 | N 22 | black | 13 | B65659-F3-X23 |
| | 400 | c | 2,82 × 4,4 | N 22 | yellow | 11 | B65659-F4-X23 |
| Adjusting screwdriver | | | | | | | B63399-B4 |
| Handle | | | | | | | B63399-B5 |

Adjusting screws

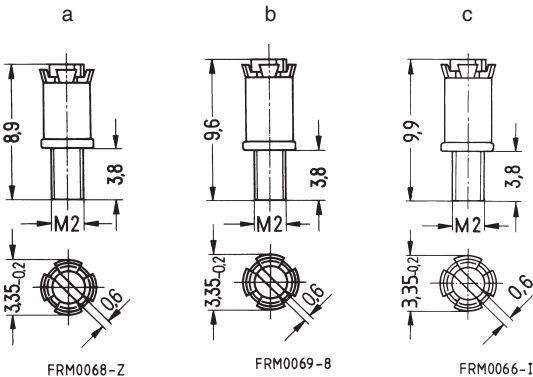

Herausgegeben von EPCOS AG

Marketing Kommunikation, Postfach 80 17 09, 81617 München, DEUTSCHLAND

© EPCOS AG 2000. Alle Rechte vorbehalten. Vervielfältigung, Veröffentlichung, Verbreitung und Verwertung dieser Broschüre und ihres Inhalts ohne ausdrückliche Genehmigung der EPCOS AG nicht gestattet.

Mit den Angaben in dieser Broschüre werden die Bauelemente spezifiziert, keine Eigenschaften zugesichert. Bestellungen unterliegen den vom ZVEI empfohlenen Allgemeinen Lieferbedingungen für Erzeugnisse und Leistungen der Elektroindustrie, soweit nichts anderes vereinbart wird.

Diese Broschüre ersetzt die vorige Ausgabe.

Fragen über Technik, Preise und Liefermöglichkeiten richten Sie bitte an den Ihnen nächstgelegenen Vertrieb der EPCOS AG oder an unsere Vertriebsgesellschaften im Ausland.

Bauelemente können aufgrund technischer Erfordernisse Gefahrstoffe enthalten. Auskünfte darüber bitten wir unter Angabe des betreffenden Typs ebenfalls über die zuständige Vertriebsgesellschaft einzuholen.

Published by EPCOS AG

Marketing Communications, P.O. Box 80 17 09, 81617 Munich, GERMANY

© EPCOS AG 2000. All Rights Reserved. Reproduction, publication and dissemination of this brochure and the information contained therein without EPCOS' prior express consent is prohibited.

The information contained in this brochure describes the type of component and shall not be considered as guaranteed characteristics. Purchase orders are subject to the General Conditions for the Supply of Products and Services of the Electrical and Electronics Industry recommended by the ZVEI (German Electrical and Electronic Manufacturers' Association), unless otherwise agreed.

This brochure replaces the previous edition.

For questions on technology, prices and delivery please contact the Sales Offices of EPCOS AG or the international Representatives.

Due to technical requirements components may contain dangerous substances. For information on the type in question please also contact one of our Sales Offices.