



Spec No.	Date	Page	Ver.
A-Z-006-00	2005/12/7	1/10	D-01

# Super Flux LED

**PART NO. : EOZ-ZIYPCD0-TK**

**Product Description**

Super Flux LEDs are made with super high brightness LED chips and low thermal resistance package. The package with low thermal resistance allows the lighting designers to drive these LEDs at higher current than the conventional through-hole LEDs. The advanced AlInGaP technology provides extremely high and stable light output over long period of time. With qualified advanced designed AlInGaP chips, EOI Super Flux LEDs can generate the same level of optical performance as it is by Lumileds' TS grade Piranha. Because Super Flux LED can emit more light, uniform and unique illuminated appearance, as it allows the lighting designer to reduce the number of LEDs required through the efficient optical design and high-current electrical design.

Excellence opto-electronics Inc. uses the brightest Red, Amber, Blue, and Green LED chips in this product family. The designers can select the most suitable color for many lighting applications, such as automobile signals, garden lightings, special lightings for building and electronic signs, and etc.



EOI			CUSTOMER APPROVED
ACTION	NAME	DATE	
PREPARED	<i>Cathy Huang</i>	<i>2005/12/7</i>	
CHECKED	<i>Vincent Huang</i>	<i>2005/12/7</i>	
APPROVED	<i>Ader Wu</i>	<i>2005/12/7</i>	

Spec No.	Date	Page	Ver.
A-Z-006-00	2005/12/7	2/10	D-01

# PART NO : EOZ-ZIYPCD0-TK

## Features

- ◆ High Luminance
- ◆ Low Thermal Resistance
- ◆ Low Profile
- ◆ Meet SAE/ECE/JIS Automotive Color Requirements
- ◆ Design for High Current Operation
- ◆ Pb free & RoHS Compliant Product

## Applications

- ◆ Automotive Exterior Lighting
- ◆ Electronic Signs and Signals
- ◆ Specialty Lighting
- ◆ Decoration

## Benefits

- ◆ Fewer LED Requirement
- ◆ Lower Application Cost

## Outline Drawings

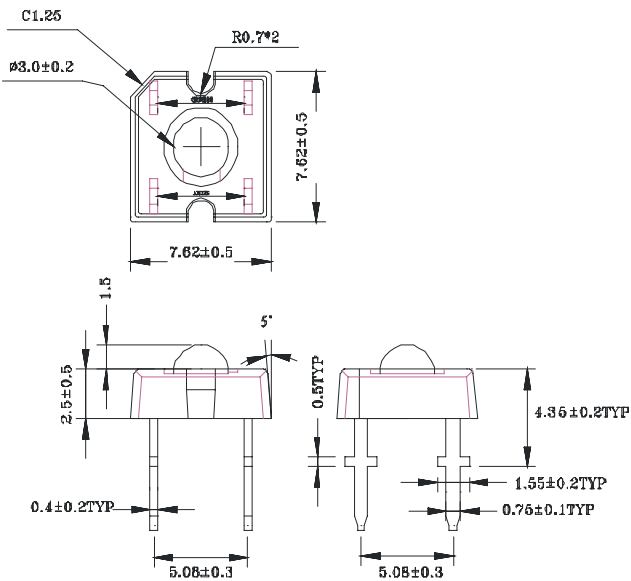

## **Notes:**

1. All dimensions are in millimeter.
2. Tolerance is  $\pm 0.20\text{mm}$  unless otherwise noted.
3. Protruded resin under bottom surface of epoxy is 1.5mm max.
4. Lead spacing is measured where the leads emerge from the package.

## Beam Pattern

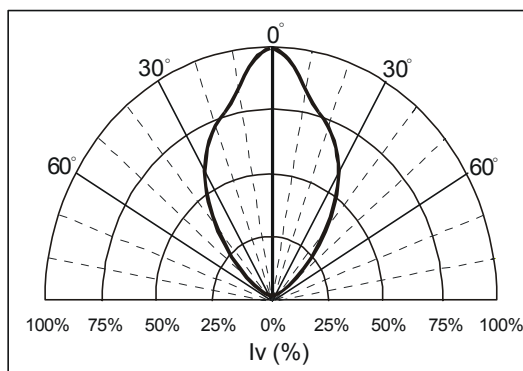

# PART NO : EOZ-ZIYPCD0-TK

Spec No.	Date	Page	Ver.
A-Z-006-00	2005/12/7	3/10	D-01

## Absolute Maximum Ratings at $T_A=25^\circ\text{C}$

Parameter	MAX.	Unit
DC Forward Current <sup>[a]</sup> ( $I_F$ )	70	mA
Power Dissipation	224	mW
Current Reduction vs. Ambient Temperature	- 0.87	mA/ $^\circ\text{C}$
Reverse Voltage ( $V_R$ )	10	V
LED Junction Temperature	125	$^\circ\text{C}$
Operating Temperature Range <sup>[b]</sup>	-40 to + 85	$^\circ\text{C}$
Storage Temperature Range	-40 to +100	$^\circ\text{C}$
Lead Soldering Condition [4mm(.157") away from epoxy]	260 $\pm$ 5 $^\circ\text{C}$ for 5 Seconds	

**Note:** [a] Design of heat dissipation should be considered.

[b] The allowable operating current at different operation temperature, please take reference from Fig 4 page 4.

## Electrical and Optical Characteristics at $T_A=25^\circ\text{C}$

Parameter	Symbol	Min.	Typ.	Max.	Unit	Test Condition
Total Luminous Flux	$\Phi_V$	2000	2500	---	mlm	$I_F=70\text{mA}$
Luminous Intensity / Total Flux	$I_V / \Phi_V$	---	1.0	---	mcd / lm	$I_F=70\text{mA}$
Viewing Angle	$2\theta_{1/2}$	---	70	---	Deg	$I_F=70\text{mA}$
Total Included Angle	$\theta_{0.9}$	---	100	---	Deg	$I_F=70\text{mA}$
Dominant Wavelength	$\lambda_d$	585	589	595	nm	$I_F=70\text{mA}$
Spectra Half width	$\Delta\lambda$	---	25	---	nm	$I_F=70\text{mA}$
Forward Voltage	$V_F$	2.0	2.7	3.2	V	$I_F=70\text{mA}$
Reverse Current	$I_R$	---	---	100	$\mu\text{A}$	$V_R=10\text{V}$
Thermal Resistance $\theta_{j-a}$	250 (Typ.)				$^\circ\text{C}/\text{W}$	$I_F=70\text{mA}$
Thermal Resistance $\theta_{j-pin}$	155 (Typ.)				$^\circ\text{C}/\text{W}$	$I_F=70\text{mA}$

## Ranks Combination

Dominant Wavelength $\lambda_D$ (nm) @ $I_F=70\text{mA}$			Total Flux $\Phi_V$ (mlm) @ $I_F=70\text{mA}$			Forward Voltage $V_F$ (v) @ $I_F=70\text{mA}$		
Code	min	max	Code	min	max	Code	min	max
Y3	585	589	2D	2000	2750	B	2.0	2.2
Y4	589	592	2E	2750	3850	C	2.2	2.4
Y5	592	595	2F	3850	5400	D	2.4	2.6
-	-	-	-	-	-	E	2.6	2.8
-	-	-	-	-	-	F	2.8	3.0
-	-	-	-	-	-	G	3.0	3.2

### **Note:**

- Viewing angle 0.9V is the included dangle at which 90% of total luminous flux is captured.
- All ranks of total luminous flux will be included in every shipment.
- Measurement Uncertainty of the Total flux:  $\pm 15\%$
- Measurement Uncertainty of the Dominant Wavelength:  $\pm 1\text{nm}$
- Measurement Uncertainty of the Voltage:  $\pm 0.05\text{V}$

Spec No.	Date	Page	Ver.
A-Z-006-00	2005/12/7	4/10	D-01

# PART NO : EOZ-ZIYPCD0-TK

## Typical Electrical / Optical Characteristics Curves

(25°C Ambient Temperature Unless Otherwise Noted)

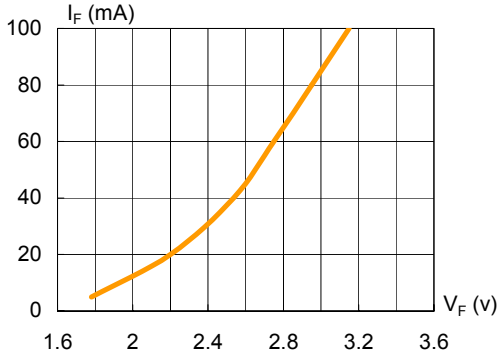

Fig.1 Forward Current vs. Forward Voltage

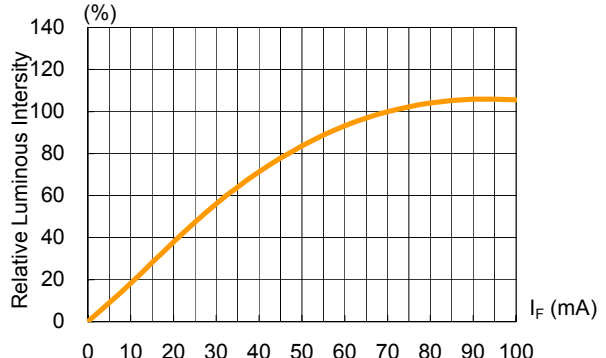

Fig.2 Luminous Intensity vs. Forward Current

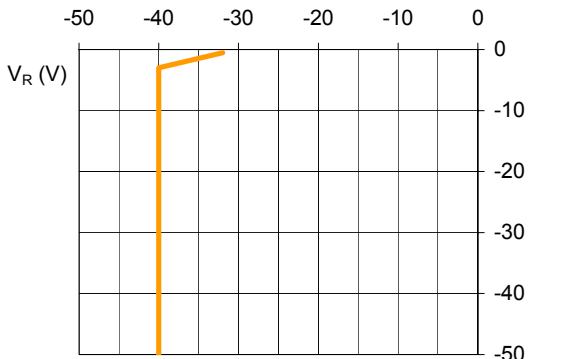

Fig.3 Reverse Current vs. Reverse Voltage

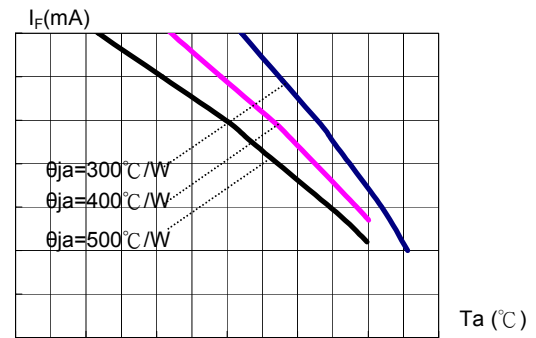

Fig.4 Allowable Forward Current vs. Ambient Temperature

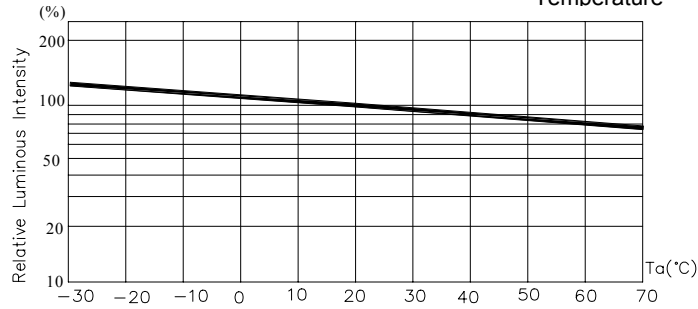

Fig.5 Luminous Intensity at I<sub>F</sub>=70mA vs. Ambient Temperature

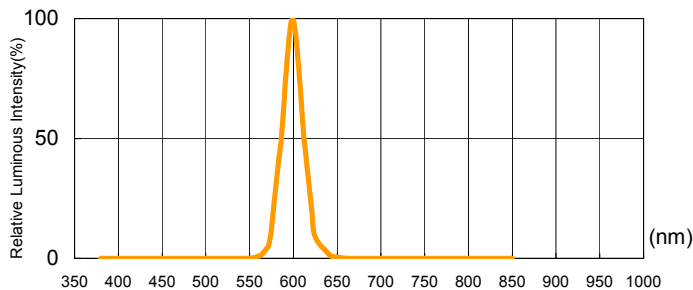

Fig.6. Relative Luminous Intensity vs. Wavelength

**\*Note: The data shown above are typical curves. Every LED component may have some variations of characteristics.**

# PART NO : EOZ-ZIYPCD0-TK

## Reliability Criteria & Results

EOI'S LED Lamps passes the reliability test in compliance with MIL standards.

### 1. Test Conditions, Accept Criteria & Results:

Classification	Test Item	Standard Test Method	Test Conditions	Duration	Unit	Acc/Rej Criteria
Life Test	Operation Life Test (OLT)	MIL-STD-750D Method 1026.3	Ta=25°C ; I <sub>F</sub> =70mA (*)	1000hrs	100 pcs	0/1
Environment Test	High Temperature Storage (HTS)	MIL-STD-750D Method 1032.1	Ta=100°C	1000hrs	100 pcs	0/1
	Low Temperature Storage (LTS)	MIL-STD-750D Method 1032.1	Ta= -40°C	1000hrs	100 pcs	0/1
	Temp. & Humidity with Bias (THB)	MIL-STD-750D Method 103B	Ta=85% ; Rh=85% ; I <sub>F</sub> =45mA (**)	500hrs	100 pcs	0/1
	Thermal Shock Test (TST)	MIL-STD-750D Method 1056.1	0 °C ~ 100°C 2min 2 min	100cycles	100 pcs	0/1
	Temperature Cycling Test (TCT)	MIL-STD-750D Method 1051.5	-40°C~25°C~100°C~25°C 30min 5min 30min 5min	100cycles	100 pcs	0/1
Mechanical Test	Solderability	MIL-STD-750D Method 2026.4	235±5°C ; 5sec	1 time	20 pcs	0/1
	Resistance to Soldering Heat	MIL-STD-750D Method 2031.1	260±5°C ; 10sec	1 time	20 pcs	/1
	Lead Integrity	MIL-STD-750D Method 2036.3	Load 2.5N(0.25kgf) 0° ~90° ~ 0° bend	3 times	20 pcs	0/1

Remark:

(\*) I<sub>F</sub> = 70 mA for AllnGaP chip ; I<sub>F</sub> = 50 mA for InGaN chip

(\*\*) I<sub>F</sub> = 45 mA for AllnGaP chip ; I<sub>F</sub> = 30 mA for InGaN chip

### 2. Failure Criteria (Ta =25°C):

Test Item	Symbol	Test Conditions	Criteria for Judgement	
			Min.	Max.
Luminous Intensity	I <sub>V</sub>	I <sub>F</sub> = 70mA (*)	LSL×0.3 **	
Voltage (Forward)	V <sub>F</sub>	I <sub>F</sub> = 70mA (*)		USL × 1.1*

(\*) I<sub>F</sub> = 70 mA for AllnGaP chip ; I<sub>F</sub> = 50 mA for InGaN chip

\*USL : Upper Standard Level

\*\* LSL : Low Standard Level

Spec No.	Date	Page	Ver.
A-Z-006-00	2005/12/7	6/10	D-01

# PART NO : EOZ-ZIYPCD0-TK

## Shipment Package

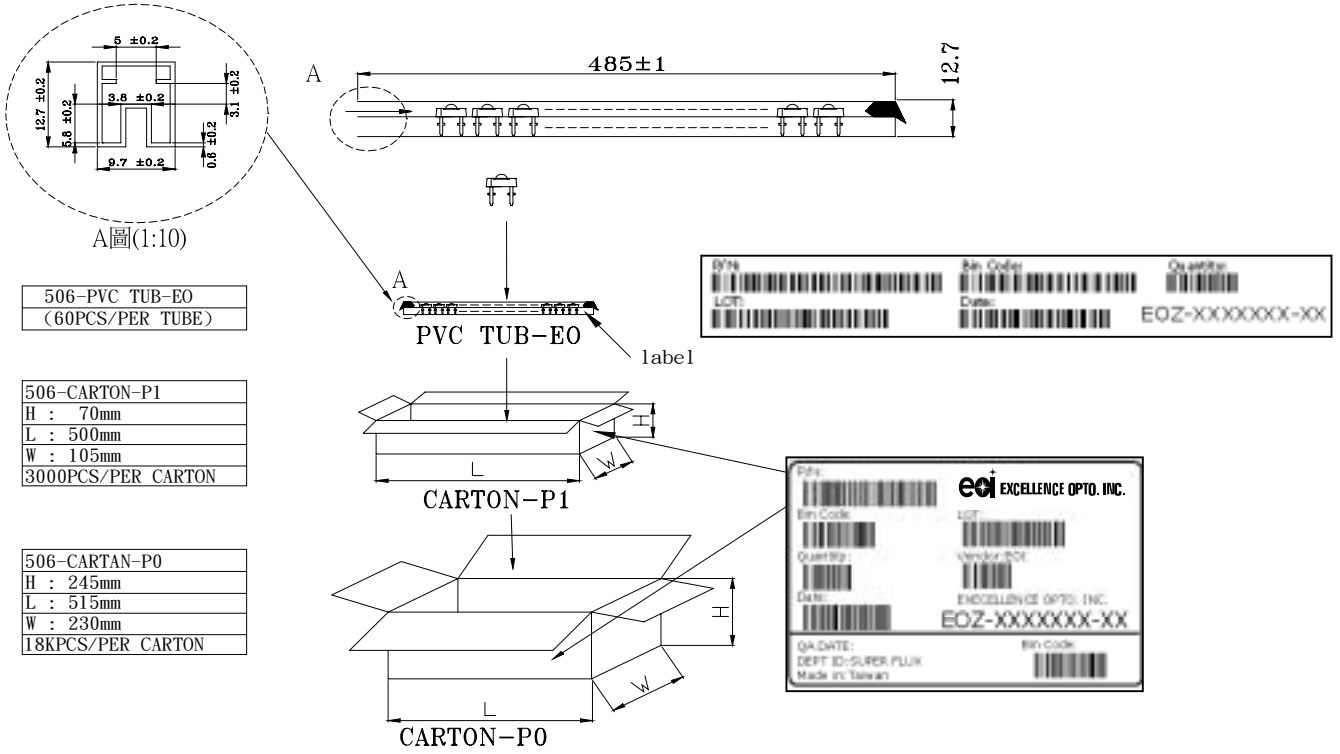

506-PVC TUB-EO (60PCS/PER TUBE)
------------------------------------

506-CARTAN-P1
H : 70mm
L : 500mm
W : 105mm
3000PCS/PER CARTON

506-CARTAN-P0
H : 245mm
L : 515mm
W : 230mm
18KPCS/PER CARTON

## Precaution of Application

### 1. Circuit layout

Due to the circuit design is not available, assuming the LED are used in parallel and one resistor that is put in series in the circuit, it may not provide an effective current-limiting function to the LEDs due to each LED has its own inherent resistance, maybe the resistance of each other is different. Different inherent resistance will cause different current; the LED on the different path would be driven at different power. If one LED with a higher resistance, it would be dimmer than the others.

To solve this situation, a suitable resistor is put in series with each LED to limit the current disparity through the LED will be very useful.

# PART NO : EOZ-ZIYPCD0-TK

Spec No.	Date	Page	Ver.
A-Z-006-00	2005/12/7	7/10	D-01

## 2. Electric Static Discharge (ESD) Protection

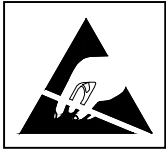

ESD protection for GaP and AlGaAs chips are still necessary even though they are safety in low static-electric discharge. Material in AlInGaP, GaN, or/and InGaN chips are STATIC SENSITIVE device. ESD protection shall be considered and taken in the initial design stage.

If manual work/process is needed, please ensure the device is well protective from ESD within all the process.

## 3. Lead Forming

The leads should not be bent at the point of 3mm or above from the base of the epoxy bulb while forming the leads.

Do not apply any bending stress to the base of the lead, and don't cause any stress after mounting the LED lamp on PCB. The stress to the base may damage the LED's characteristics, or cause deterioration of the epoxy resin. This will hurt and degrade the LEDs.

## 4. Storage

It's recommended to store the products in the following conditions:

Humidity: 60%RH Max.

Temperature: 5°C ~ 30°C ( 41°F ~ 86°F )

Shelf life in sealed bag: 12month at <40°C and <30%RH.(Base on aluminum laminated moisture barrier bag.) If the LEDs are stored for 3 months or more, the nitrogen atmosphere storage environment is recommended.

Although the leads of LED lamp is platted with pure tin to protect leads from corrosion, devices should be subjected to wave soldering, or equivalent process as soon as possible, after the bag is opened.

Please avoid rapid transitions in ambient temperature, especially in high humidity environment where condensation can occur.

Spec No.	Date	Page	Ver.
A-Z-006-00	2005/12/7	8/10	D-01

# PART NO : EOZ-ZIYPCD0-TK

## 5. Soldering

Soldering heat may damage the LED. Careful attention should be paid during soldering process.

Solder the LEDs no close than 3mm form the base of the epoxy bulb.

Recommended SnPb reflow soldering profile:

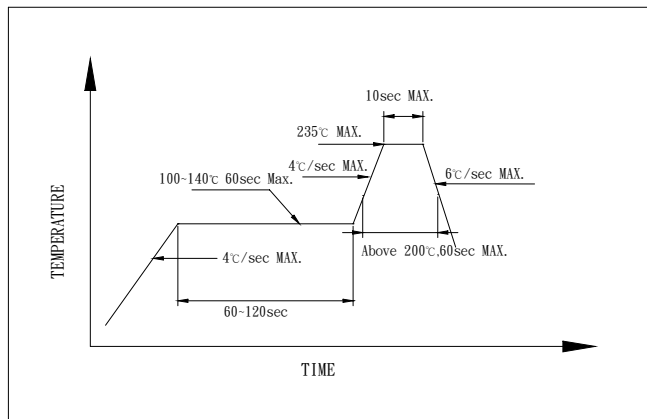

Recommended Pb free reflow soldering profile:

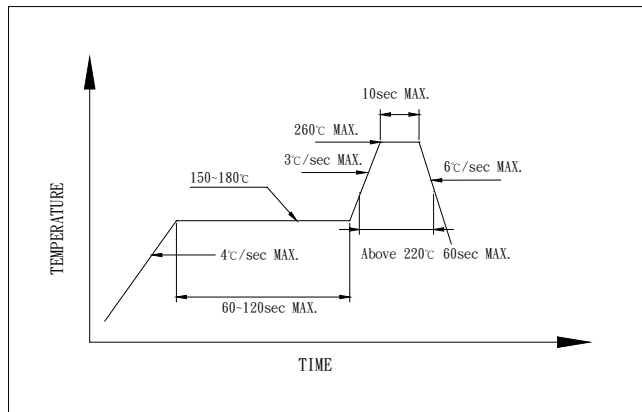

Never take next process until the component is cooled down to room temperature after soldering. It's banned to load any stress on the resin during soldering. If it's necessary to clamp the LED bulbs to help soldering, it is important to minimize the mechanical stress on the LEDs.

The manual soldering process is not recommended for quality consideration. When it is absolutely necessary, the LEDs may be mounted in this fashion but the user will assume responsibility for any problems.



# PART NO : EOZ-ZIYPCD0-TK

Spec No.	Date	Page	Ver.
A-Z-006-00	2005/12/7	9/10	D-01

## 6. Cleaning

An alcohol-based solvent such as isopropyl alcohol (IPA) is recommended to clean the LED bulbs, after soldering process. Before cleaning, a pre-test should be done to confirm whether any damage to the LEDs will occur.

## 7. Others

Heat generation:

- LED lamp is very sensitive to heat. Thermal design of the end product will decide the performance of LED lamps. It's necessary to avoid intense heat generation and operate within the maximum ratings given in this specification.
- PCB Layout of LEDs can be considered to enhance the heat dissipation. Please enlarge the copper area at the cup (cathode) side of LEDs. The larger copper trace of PCB will help thermal dissipation, when LED is turned on.

# PART NO : EOZ-ZIYPCD0-TK

Spec No.	Date	Page	Ver.
A-Z-006-00	2005/12/7	10/10	D-01

## Terms and Condition

1. EOI warrants all sold LEDs which conform to the specifications approved by the customers.
2. Any LED supplied by EOI is found not conform to the specifications that both parties agreed upon, customer should claim within 90days of receipt. EOI will repair or replace the LEDs at EOI's option.
3. EOI will not hold any responsibility for the failed LEDs, which are caused by mishandling or using the LEDs exceeding the operating conditions that EOI suggested.
4. EOI's LED products are designed and manufactured for general electronic equipment (such as household appliances, communication equipment, office equipment, electronic instrumentation and so on). If customer's application requires exceptional quality or reliability, which might concern human safety, it is recommended to consult with EOI in advance.
5. All the information published is considered to be reliable. However, EOI does not assume any liability arising out of the application or use of any product described herein. EOI's liability for defective LED lamps shall only be limited to replacement, in no event shall EOI be liable for consequential damages or profit lose.
6. EOI and customer shall both confirm the specifications herein, and all quality related matters will base on the specifications both parties agreed upon.
7. Any modification of the design or manufacturing process taken place, which will affect the characteristics, performance or reliability of LED, customer's approval will be required.
8. This specification approval sheet is an agreement of shipment specification. Please sign it back and keep the copies in two parties. If customers don't sign it back, it is regarded as completely agree with the terms and conditions and also approve of this approval sheet.

## Company Information

### Head Quarter

5F, No. 1, Creation Road II, Hsinchu Science Park,  
HsinChu, Taiwan 300, R.O.C.

TEL: 886-3-5679000

FAX: 886-3-5679999

<http://www.eoi.com.tw>

E-mail: [Service@eoi.com.tw](mailto:Service@eoi.com.tw)



### US Office

1400 W. Lambert Road, Suite #B, Brea CA 92821

TEL:(562) 694-1246, (562) 694-1427

FAX:(562) 691-3087

Sales Team: [sales@eoius.com](mailto:sales@eoius.com)